

DIN125 A 16	5	DIN934 M16	RINA
DIN125 A 16	5	DIN934 M16	LR
DIN125 A 16	5	DIN934 M16	GL
DIN125 A 16	5	DIN934 M16	DNV
DIN125 A 16	5	DIN934 M16	BV
DIN125 A 16	5	DIN934 M16	ABS
DIN125 A 16	5	DIN934 M16	RMRS
DIN125 A 16	5	DIN934 M16	EN 12953

DESIGN TEMPERATURE	250 °C
DESIGN PRESSURE	20 bar
MAXIMUM ALLOWABLE HYDRAULIC TEST PRESSURE	35 bar

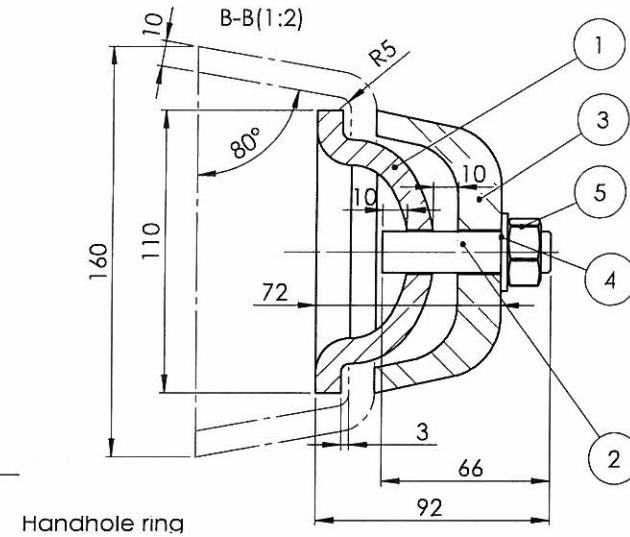
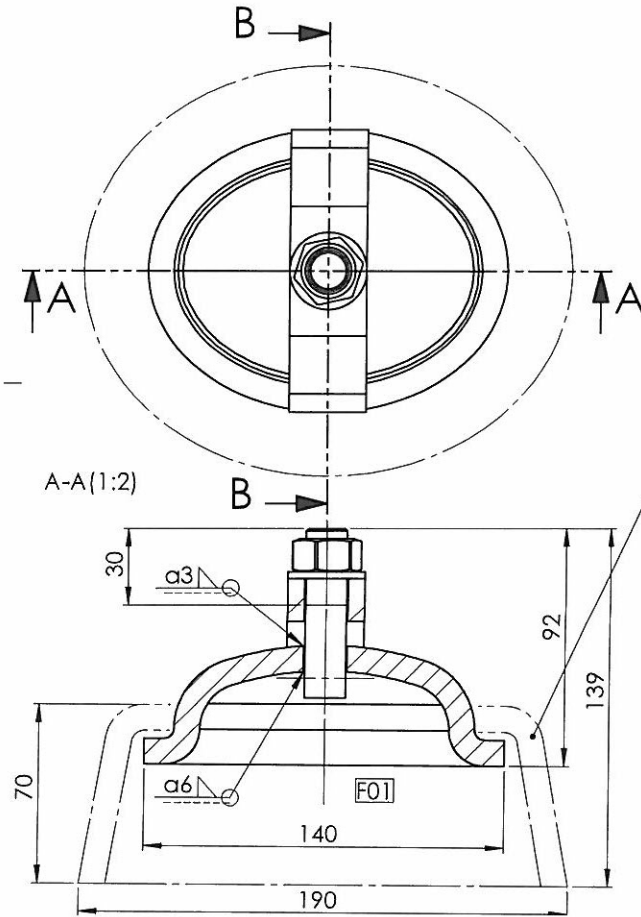

Handhole ring

Oznaka/Mark	Poz. item	Poz. item	WPS	Atest/Atest
F01	1	2	668.00.00	RINA
F01	1	2	668.00.0L	LR
F01	1	2	668.00.0G	GL
F01	1	2	668.00.0D	DNV
F01	1	2	668.00.0B	BV
F01	1	2	668.00.0A	ABS
F01	1	2	668.00.0R	RMRS
F01	1	2	668.00.0E	EN 12953

