

COMPUTER PRODUCED DRAWING - DO NOT CHANGE MANUALLY

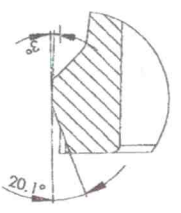
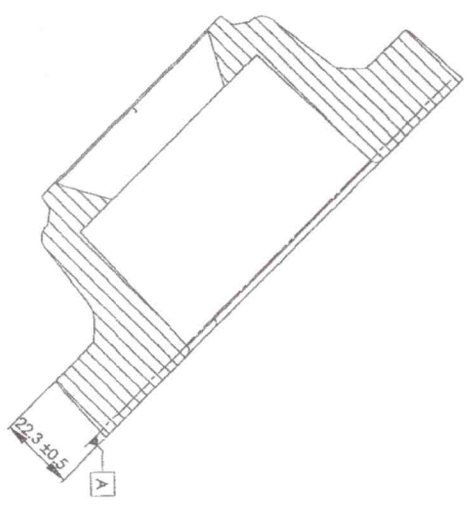
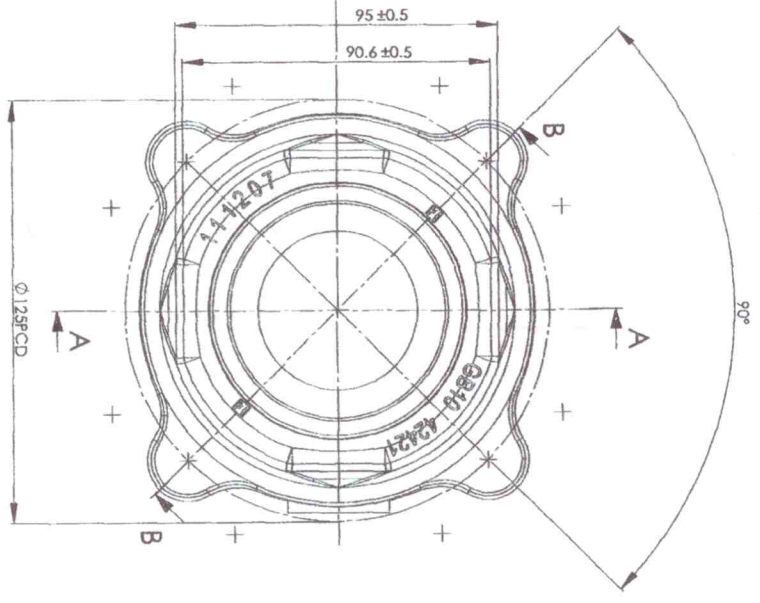
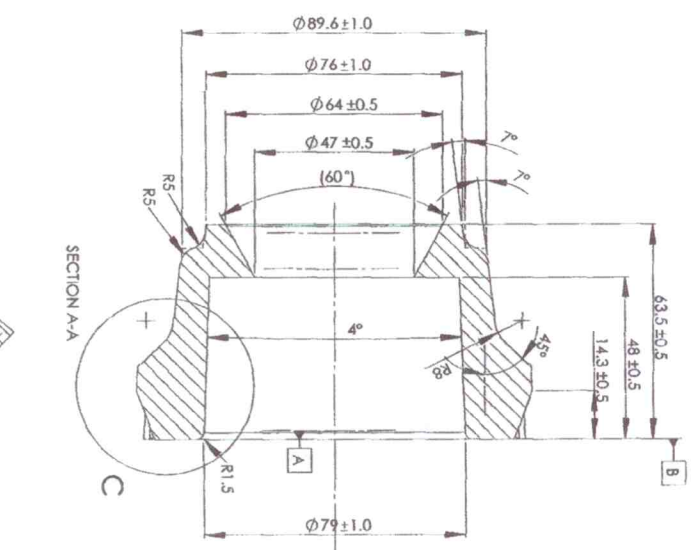

VOLUME 25,000 / MONTH
 CAST WT 2,3 KG

1. PRODUCTION ISO METHOD A
 2. 51 UNITS
 3. SURFACE TO GO R110 (DN/B)
 4. SURFACE FINISH TO BS 1580
 5. MACHINE WHEEL SHOWN
 6. DIMENSIONS ARE TO UNLESS OTHERWISE SPECIFIED
 7. DO NOT DIMENSION SPREADS UNLESS OTHERWISE SPECIFIED
 8. DIMENSIONS APPLY AFTER PLATING
 9. GEOMETRIC TOLERANCES TO BS 11065
 10. ABERRATIONS TO BS 11001
 11. SURFACE TOLERANCES TO BS 11065
 12. WELD SYMBOLS TO BS 499
13. METHOD OF PRODUCTION AND SUPPLIER MUST BE APPROVED BY ENGINEERING APPROVAL OF PRODUCTION MANAGER MUST BE APPROVED BY ENGINEERING APPROVAL OF PRODUCTION MANAGER
 14. GENERAL TOLERANCES TO BS 11065
 15. SURFACE FINISH TO BS 1580
 16. DO NOT SCALE DRAWINGS

TECHNICAL SPECIFICATIONS		TITLE	
DESIGN AUTHORITY	GIRDOCKSA	SCALE	2:1
DRAWN	VEE	CHECKED	PANDUAY
DATE	2008/03/12	DATE	
ST. CHANGE	1	DATE	
SIGN		SIGN	
SUPPLIER	FCDKDD-A	CASTING	
MATERIAL	FCDKDD-A	HEAT TREATMENT	
FINISH		PRE/DWG	

SHEET		TITLE	
QF	A2	BEARING CASE CASTING	
		42421-0K030	
		A	