

A

B

C

D

REV.	DESCRIPTION	DATE	ECO #	BY	APRV'D
0	INITIAL RELEASE	07/31/09	----	JAP	
1	CHANGED MATERIAL OF HEX BOLT FROM SS TO BLK ZINC	08/18/09	7532	JAP	
2	ADDED WASHER, 1/2" WAS 3/8"	09/08/09	7544	JAP	
3	REMOVED WASHER	10/22/09	7582	JAP	
4	ADDED REVISION COLUMN TO BOM TABLE, DCI127998 CHG FROM REV 3 TO REV4	11/02/09	7587	JAP	
5	DCI127998 CHANGED FROM REV 4 TO 5	11/04/09	7588	JHB	
6	CHANGED ASSEMBLY NOTE	12/04/09	7612	JHB	

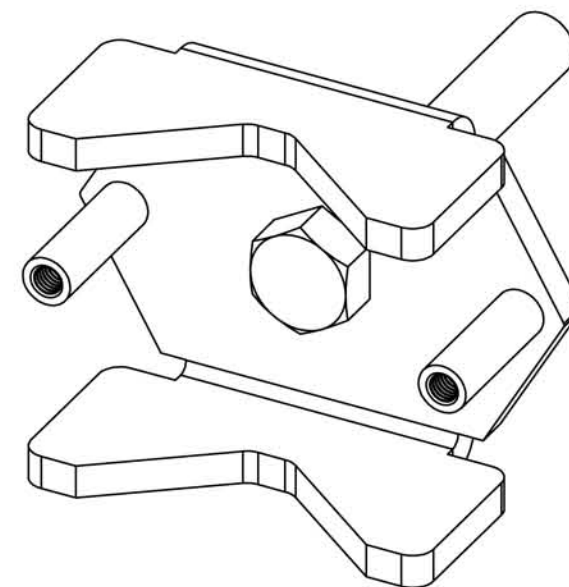
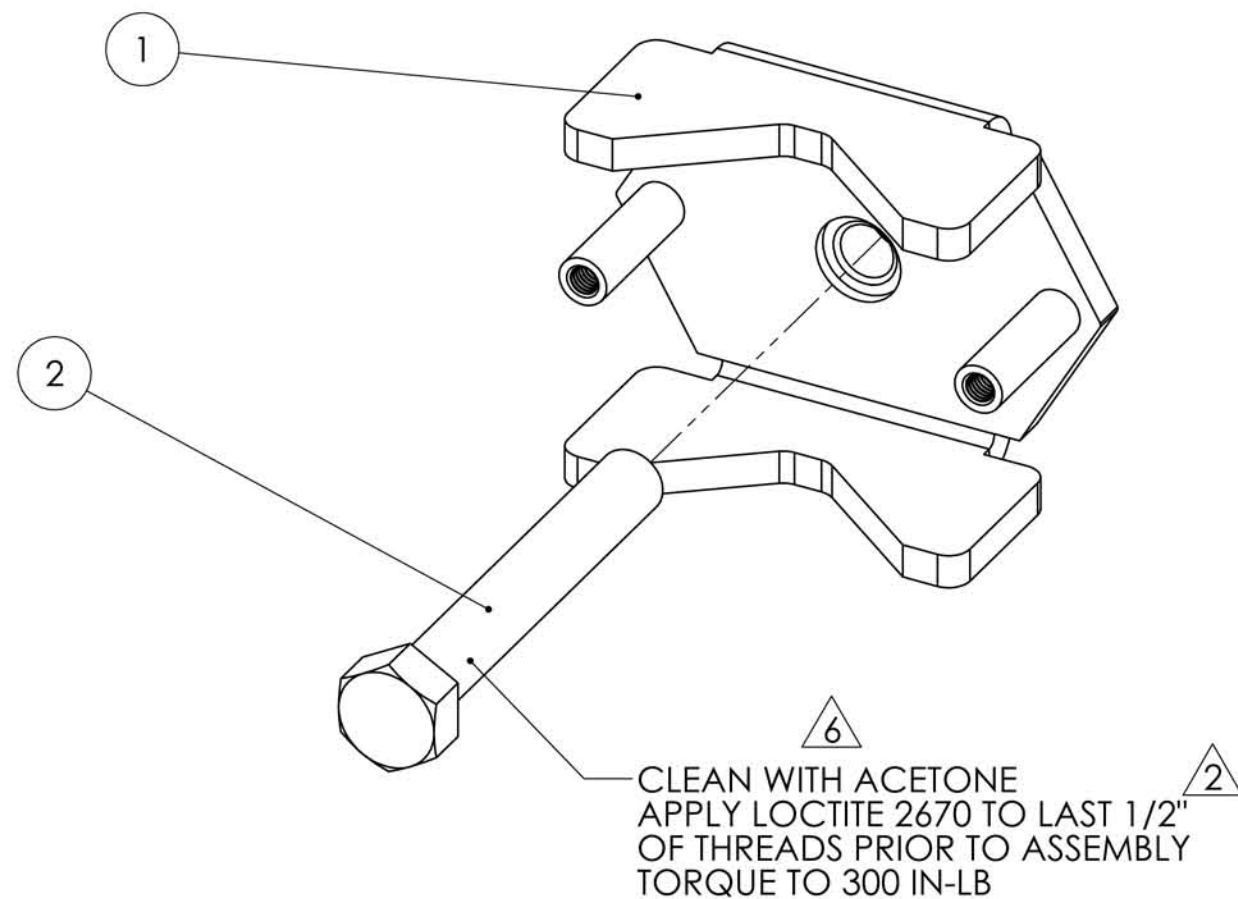

2	HBOLT 0.3750-16x2.5x2.5-NSTL ZN		HEX BOLT, 3/8-16, 2.5" LONG, BLK ZINC	1
1	dc127998	6	HEXPLATE	1
ITEM NO.	PART NUMBER	Revision	DESCRIPTION	QTY.

BOM Table

UNLESS OTHERWISE SPECIFIED DIMENSIONS ARE IN INCHES TOLERANCE ARE:		DO NOT SCALE THIS DRAWING		 10895 NW 50TH STREET SUNRISE FL 33351 PHONE: 954-746-0547 FAX: 954-746-3001	
DECIMALS .XX ± .01 .XXX ± .005	FRACTIONS ±1/64	ANGLES ±0°30'	DRAWN J. PIETROVITO	TITLE ASSEMBLY, HEXPLATE WITH BOLT	
REMOVE BURRS & SHARP EDGES			DATE 07/31/09	APPROVED -	
ALL MACHINED SURFACES \checkmark 63			DATE -	DATE -	
MATERIAL N/A	FINISH N/A		PROPRIETARY AND CONFIDENTIAL THE INFORMATION CONTAINED IN THIS DRAWING IS THE SOLE PROPERTY OF J&L INDUSTRIES INC. ANY REPRODUCTION IN PART OR AS A WHOLE WITHOUT THE WRITTEN PERMISSION OF J&L INDUSTRIES INC IS PROHIBITED		SIZE B
			DRAWING NUMBER dc127999		REV. 6
			SCALE: 1:1		SHEET 1 OF 1

A

B

C

D