

WHEN IN DOUBT ASK

ALL DIMENSIONS ARE IN mm
UNLESS OTHERWISE STATED

DRAWING ALTERATIONS

ISSUE NO & DATE	A NOTE NO	ALTERATIONS
01 08.01.2009		Alternative Design Added. Issue No. was 00

OUTER PERIPHERY

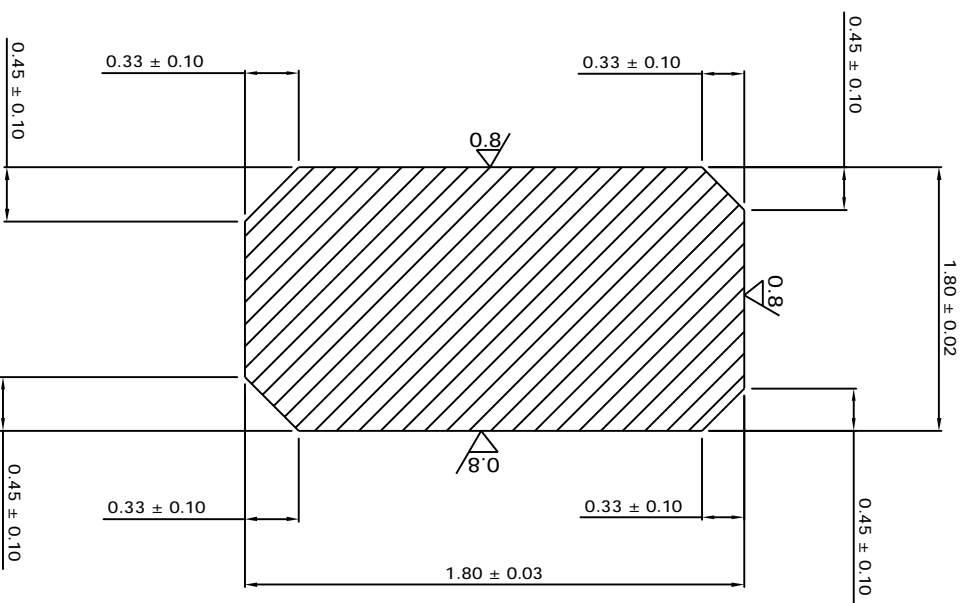

INNER PERIPHERY

ALTERNATIVE DESIGN

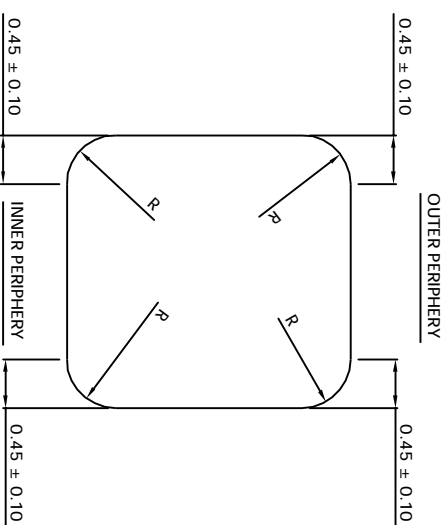

Corners to be free from burrs
All Surfaces are to be free from scratches
Surface Finish Values Shown Are in Mu Ra

MATERIAL :

PRECIPITATION HARDENING AUSTENITIC
STAINLESS STEEL A286 (JIS : SUH660) (DIM - 6028)

HARDNESS : 34 ~ 43 HRC

CHEMICAL COMPOSITION

Element	C	Al	B	Cr.	Mn	Mo	Ni	P	S	Si	Ti	V	OTHERS EACH	OTHERS TOTAL	Fe
Min.	---	---	.001	13.50	---	1.00	24.00	---	---	---	1.90	.100	---	---	Balance
Max.	0.08	0.35	.010	16.00	2.00	1.50	27.00	.040	.030	1.00	2.35	.500	1.00	2.00	

IP Rings Ltd.
Maraimalai Nagar – 603 209.



NAME	DATE
DRAWN P.A.RAU	17.12.2008
CHECKED RC	17.12.2008
APPROVED UK	17.12.2008

SCALE	TYPE & MODEL	DRG. NO.	ISSUE NO.
NTS	A286 STEEL WIRE 1.80 X 1.80	SW-HW-A286-00	01